

FRONT VIEW ELEVATION

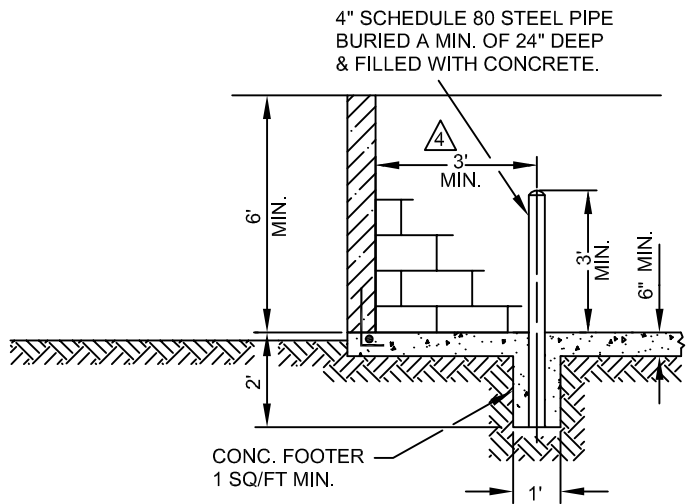

SIDE VIEW ELEVATION

- NOTES:
1. GATES WITH MIN. CLEAR OPENING OF 12' (SINGLE) OR 19' (DOUBLE) REQUIRED.
 2. GATES SHALL BE CONSTRUCTED WITH AN OPAQUE MATERIAL FOR SCREENING PURPOSES. TYPE OF MATERIAL IS AT OWNER'S DISCRETION.
 3. A CERTIFIED HOLD HARMLESS AGREEMENT MUST BE PROVIDED PRIOR TO CONSTRUCTION OF THE ENCLOSURE AND OR GATE.
 4. LOCATION AND ORIENTATION OF THE DUMPSTER PAD MUST BE APPROVED BY THE REFUSE DEPT. PRIOR TO THE ISSUANCE OF A CONSTRUCTION PERMIT.

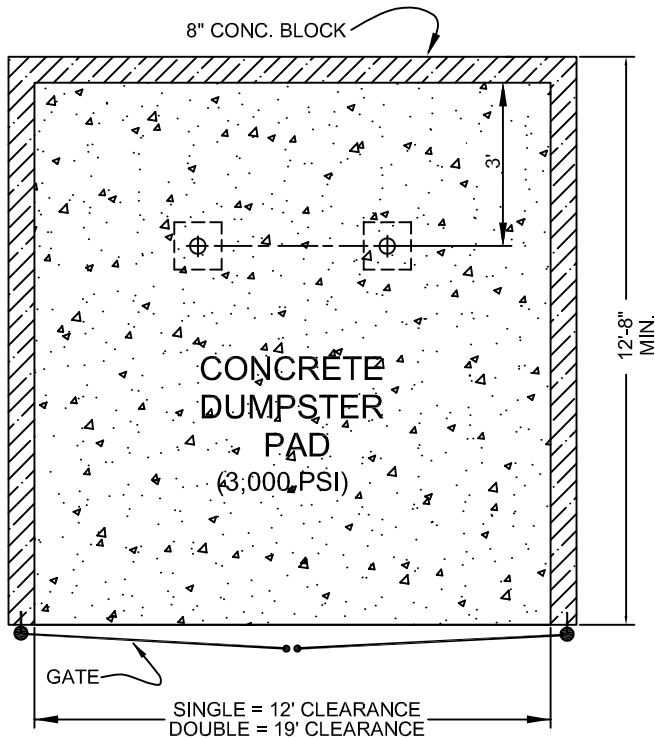
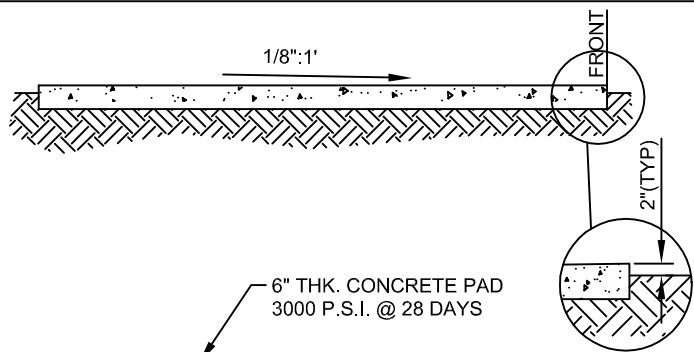

PLAN VIEW

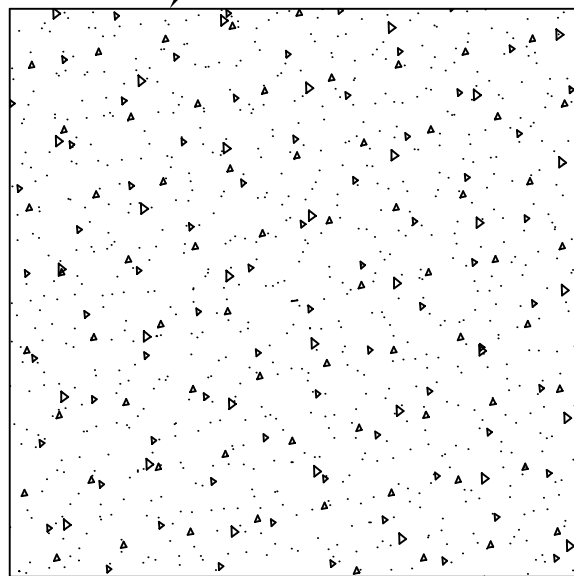

WINTER HAVEN
The Chain of Lakes City

STANDARD DETAIL

**CITY STANDARD DUMPSTER PAD
MINIMUM REQUIREMENTS FOR
ENCLOSURES WITHOUT RECYCLING AREA**

REVISED	DATE	SCALE	SHEET NO.	INDEX NO.
DCK	2/19/00	NTS	1 OF 1	DP 101
RD	9/14/05			
RD	5/18/09			

△
JAC 5/21/10